

1.25 Heim/Uniball Performance Upper Arm Instructions

Toyota Landcruiser 200 2wd/4wd 08-21

PARTS SUPPLIED

| QTY | DESCRIPTION | ID |
|-----|--|----|
| 4 | FK 3/4 X 3/4 RHT heim joints | 1 |
| 4 | Heim spacers (long inner) | 3 |
| 4 | Heim spacers (short outer) | 2 |
| 4 | 3/4-16 RHT steel jam nuts | 4 |
| 2 | 9/16" tapered uniball spindle adaptors | 8 |
| 2 | 9/16" upper uniball spacers | 7 |
| 2 | M16 x 1.50 nyloc nuts | 5 |
| 2 | 9/16-18 x 4" 12pt bolts | 6 |
| 2 | 9/16 SAE flat washers | 9 |
| 2 | 9/16-18 stover lock nuts | 10 |
| 2 | 10-32 x 3/4" SCHS bolts (zinc) | 11 |
| 4 | 10-32 stainless washers | 12 |
| 2 | 10-32 nyloc nuts | 14 |
| 2 | Rubber stainless insulated clamps | 13 |
| 4 | Camburg 8.5" Stickers | |

** REFER TO EXPLODED CAD DRAWING ON **
 ** OTHER SIDE FOR PARTS REFERENCE NUMBERS **

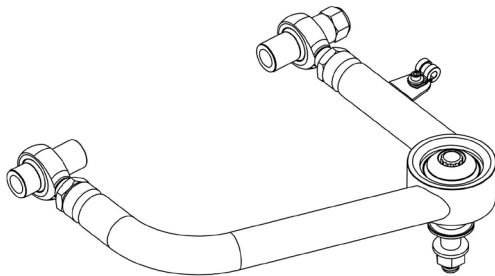

Thanks for purchasing a set of our Camburg performance upper arms for your vehicle. Please follow all instructions. If you are not installing these yourself have a qualified shop do so. These arms are designed to be used with stock unmodified spindles or Camburg performance spindles in conjunction with a 1-3" lift coilover/strut. They are not to be used with other suspension kits or spacer type kits. Make sure to check the parts list to make sure you have every component prior to starting. Camburg Engineering has made every attempt to insure you receive the highest quality components in the most complete manner. This is a guide to help you through the process with recommended torque specs. It's your responsibility to ensure parts are being installed correctly using the correct tools and procedures.

Tools & Supplies Required

Eye protection | Jack | Jack stands | Deburring tool
 2-3 lb. mini sledge hammer | Rubber mallet | Needle nose pliers
 19mm socket | 22mm socket & wrench | 24mm socket
 9/16" 12pt socket | 7/8" socket | 5/32" allen wrench | 3/8" wrench
 1-1/8" open-end wrench | Torque wrench | Brake cleaner
 Anti-seize | Red Loctite | Grease

1.0 Setup

Park the vehicle on level ground and set the parking brake and chock both rear wheels. Jack up the front end from the chassis until the front tires are off the ground. Place jack stands under the front frame rails and set down. Make sure the vehicle is supported correctly and the front tires are still off the ground. Place the jack under the driver side lower arm and raise the tire 1/2", then remove the wheel while keeping jack under lower a-arm to support the suspension. Read these instructions start to finish before moving forward and review diagrams.

2.0 Removal

Using needle nose pliers, remove the cotter pin from the upper ball-joint at the spindle. Using a 19mm socket, loosen the castle nut but do not fully remove. With a mini sledge hammer strike the top of the spindle numerous times to release the ball-joint tapered stud. This can be a little difficult since it's a press fit, heating up the spindle to get it to expand will help if need be. Once the ball joint releases from the spindle, then remove the nut. This will allow you to position the upper arm and spindle out of the way. Make sure to position & support the spindle so that it doesn't pull on the brake line and on 4wd models that it doesn't pull out the inner CV or strain the CV boots and axles. Using a 22mm socket & wrench, loosen and remove the OEM upper a-arm bolt. Remove the upper arm.

3.0 Pre-installation

Thread the 3/4" jam nuts onto the heims then apply anti-seize compound on the exposed threads. Thread the heims into the upper arm so the heim is vertical

.... and the jam nut makes contact with the arm with 3 threads exposed past the nut. Use a 1-1/8" open-end wrench to fully tighten the jam nut using another wrench to hold the heim vertical (perpendicular to the arm) so it doesn't rotate. Now install the heim pivot spacers. The longer/thicker spacers go on the insides and the shorter/thinner spacers go on the outsides. We recommend coating the surface that slips into the heim with a little anti-seize. See diagram for reference.

Using a countersink bit or deburring scraper tool, slightly chamfer the top-hole edge of the ball-joint taper in the spindle. This will allow the spacer to fully seat when tightened and eliminate possible stress risers. Then inspect and clean the tapered hole. See diagram for reference.

4.0 Installation

Install the driver side Camburg upper arm to the frame using the existing OEM M16 bolt. To insure you're installing the correct arm, the uniball snap-ring is below and the longer a-arm tube is towards the front of the vehicle with the ABS tab towards the rear. With the bolt pushed all the way through clean the threads using brake cleaner and install the supplied nyloc nut with red loctite. Using a 22mm wrench and 24mm socket, torque to 120 ft/lbs. See diagram for reference.

Prior to installing the tapered uniball adaptor spacer into the spindle, make sure the spindle taper is clean and free of debris. Apply anti-seize to the uniball spacers and insert the tapered lower uniball spacer into the uniball. Then install the upper spacer into the top of the uniball making sure both spacers are fully seated. If not, damage will occur in the following steps. Wipe off excess anti-seize and install the 9/16" 12pt bolt through the spacers and uniball and attach the upper arm to the spindle by swinging it down to the spindle with some finesse. You may need to jack up the lower arm and move the uniball joint. The tapered spacer should sit almost flush with the top of the spindle before tightening. Make sure the lower spacer did not pull out slightly from the uniball or damage will occur as the spacer can get caught on the bearing race and/or snap ring. Install the 9/16" washer and stover lock nut with a small amount of red Loctite onto clean threads. Using a 9/16" 12pt socket and 7/8" socket, torque to 120-125 ft/lbs. Do not over-tighten or use an impact gun. See diagram for reference.

Due to the extreme and punishing nature of offroad use, Camburg Engineering products have no implied or expressed warranty. Camburg Engineering products and components are designed and manufactured for offroad use only. Installing most suspension products will raise the center of gravity of the vehicle and can increase the susceptibility to a rollover and alter the handling characteristics. Camburg Engineering products may void the vehicles warranty, check with your local dealer. The loss of use of the product, loss of time, inconvenience, removal, shipping costs, commercial loss or consequential damages are not covered. Camburg Engineering reserves the right to change the design, material or specifications of any product without assuming any obligation to modify any product previously manufactured and without prior notice. Every effort has been made to avoid printing errors and specifications. By installing and/or using these products you are accepting these stated conditions and accept all liability and responsibility.

.... Using the supplied 10-32 hardware and rubber clamps, attach the speed sensor wire to the backside of the upper arm using a 5/32" allen and 3/8" wrench. Make sure to route the wire so that is has proper clearances.

Repeat steps 1 through 4 to install passenger side arm

5.0 Alignment

You will need to have your vehicle aligned by a qualified shop. Additional caster is built into the Camburg arms to correct alignment issues that are inherent with lifting the vehicle. Have your alignment shop increase/maxout positive caster, then set camber and toe to factory OEM specifications. Having an increase in caster helps with straight line stability and cornering precision for performance driving on and off-road.

6.0 Maintenance & Care

Uniballs & heims are precision parts with tight tolerances which can lead to occasional noise when they become dirty. Occasionally wipe off the top and underside of the uniball with a clean rag to remove road grime and dirt. Cleaning and lubricating them with WD-40 or a PTFE dry film lube like "Tri-Flow" can minimize any noise from stiction. Do not use harsh chemicals or grease/oils that attract dirt to clean & lube as it will damage and wear the internal PTFE liner. Neglecting care and upkeep will wear parts out faster.

Inspect and re-torque all hardware and components after 500 miles and whenever using the truck off-road.

Notes

Recommended tire size: 33" - 35"
 Recommended wheel size: 18x9
 Maximum wheel backspacing = 6.00"

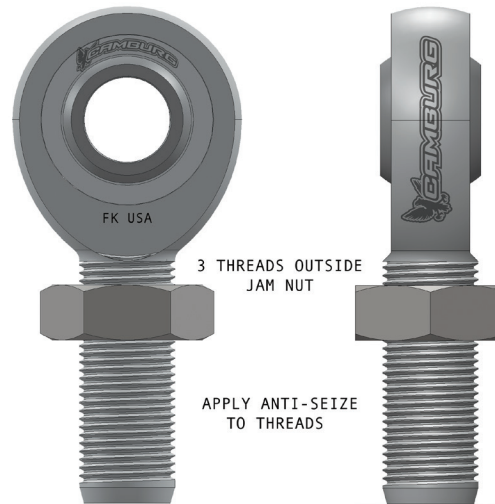
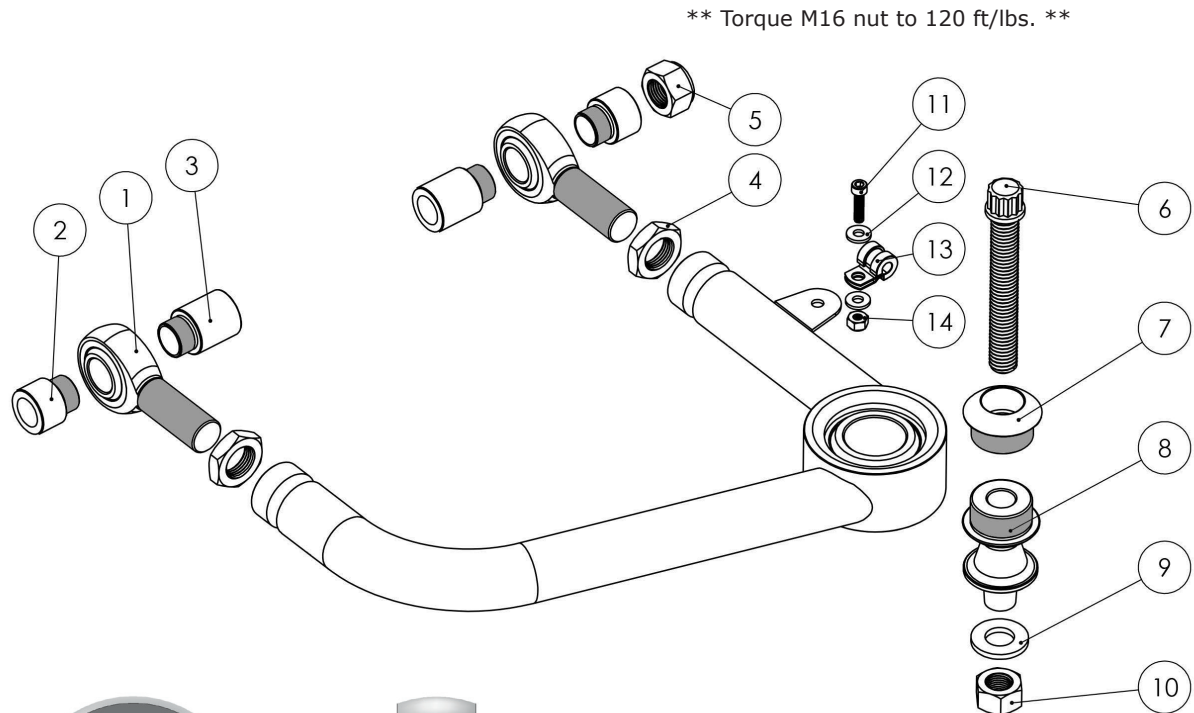
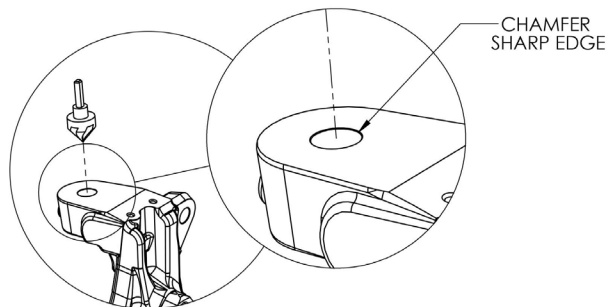

** Torque 9/16" nut to 120-125 ft/lbs. **

Due to the extreme and punishing nature of offroad use, Camburg Engineering products have no implied or expressed warranty. Camburg Engineering products and components are designed and manufactured for offroad use only. Installing most suspension products will raise the center of gravity of the vehicle and can increase the susceptibility to a rollover and alter the handling characteristics. Camburg Engineering products may void the vehicles warranty, check with your local dealer. The loss of use of the product, loss of time, inconvenience, removal, shipping costs, commercial loss or consequential damages are not covered. Camburg Engineering reserves the right to change the design, material or specifications of any product without assuming any obligation to modify any product previously manufactured and without prior notice. Every effort has been made to avoid printing errors and specifications. By installing and/or using these products you are accepting these stated conditions and accept all liability and responsibility.