

# TOYOTA TACOMA 05-19 STEERING STOP KIT

First you will need to remove the factory steering stops from the OEM Toyota lower ball-joint cradle assembly using a cutoff wheel and grinder. For corrosion resistance touch up with black paint. (See 1.1)

Then you will need to install our steering stop kit. This is needed to keep the spindle/knuckle from contacting the lower arm at full turn since it can over travel with the stops removed. Remove the inner tie rod from the steering rack and press our machined delrin spacer over the steering rack shaft like in the picture below (1.2). You can use a plastic mallet to press it on. When re-installing the inner tie rod, make sure to use red loctite and torque to manufacturer's specs. Turning radius is not noticeably different with the spacer installed. Repeat both operations on the other side.

1.1

OEM LOWER BJ CRADLE



REMOVE

1.2

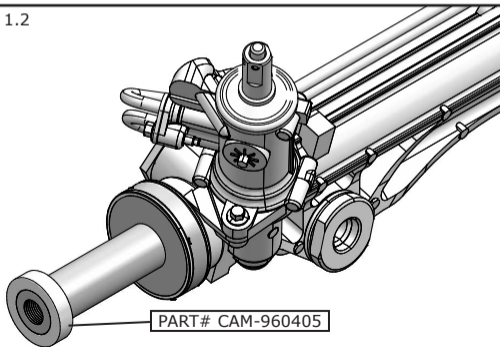

PART# CAM-960405